

850nm, Infrared Laser Module

Application

Industrial areas / Medical / Biochemical / Laser Tag

Property

Wavelength Range = 850nm (others optional)

Introduction

Egismos created high stability and quality laser modules that are successfully applied in aerospace, military industry, biochemistry, medicine etc. S8/H8 laser module series is distinguished by its compact size, high MTTF, good stability and wide wavelength selection.



Specifications(T=25°C)			
Items	Symbols	S838501D, S858501D S838505D, S858505D	H838501D/R, H858501D/R H838505D/R, H858505D/R H8385030D/R, H8585030D/R
Mode		CW	CW
Wavelength	λ	850nm	850nm
Lens		PMMA	Glass
Spot	D/R	Dot	Dot/Round
Spot Size	D R	<15x30mm at 10m	<12x15mm at 10m <15mm round at 3m
Diameter x Length	Φ x L	8X16 mm	8X20 mm
Output Power	Po	<1mW, <5mW	<1mW, <5mW, <30mw
Power Stability		<10%	<5%
Divergence Angle	mrad	<1	<0.7
Operating Voltage(DC)	Vo	3V / 5V	3V / 5V
CW Operating Current	Io	15~20mA, 40mA max	15~20mA, 30mA max(1mw,5mw) 70~80mA, 95mA max(30mw)
Operating Temperature	To	-10°C ~ +50°C	-10°C ~ +60°C
Storage Temperature	Ts	-40°C ~ +80°C	-40°C ~ +80°C
Housing Material		Brass	Brass/Aluminum
Mean time to failure		>5000 hrs	>8000 hrs

Outline Dimensions

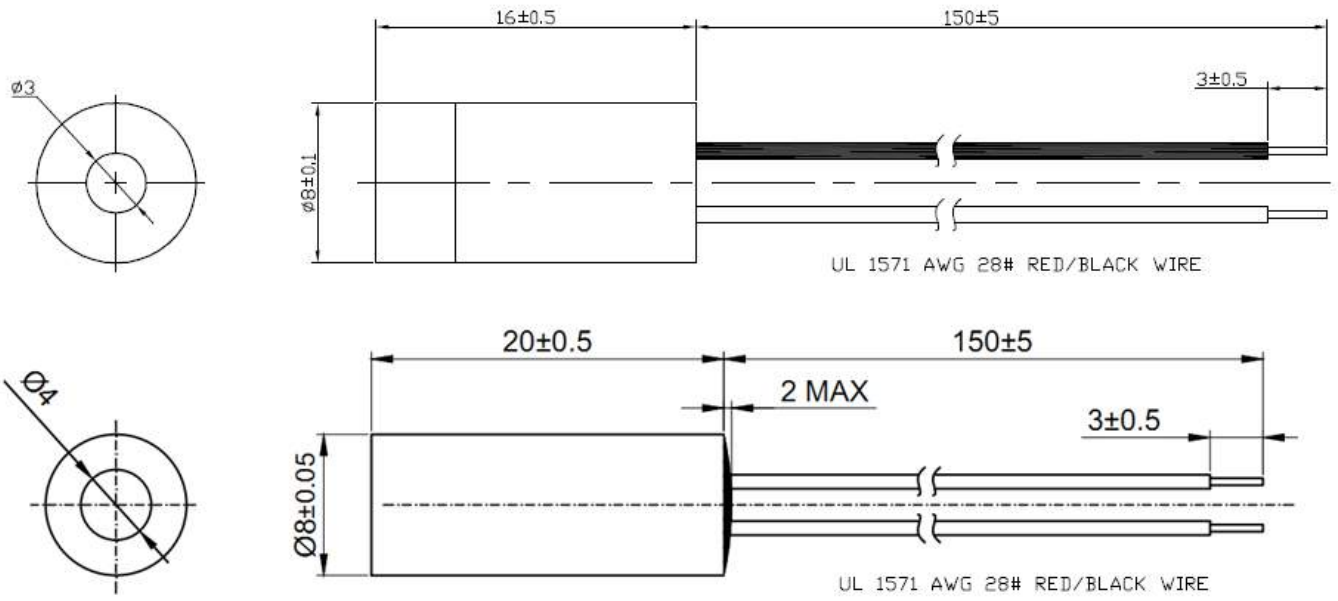

Spot size Define

S8 series Dot Shape at 10m



H8 series Round Shape at 3m



Power Stability

The actual output power will be between the range 2.5mW to 3.5mW, but once you make sure the value, for example, $3\text{mW} \pm 0.15\text{mW}$ or $3.2\text{mW} \pm 0.16\text{mW}$ in the $25\text{ }^{\circ}\text{C}$ temperature. Then the power stability represents 5%.

Spot size

The spot size is defined as a Gaussian beam. In optics, a Gaussian beam is a beam of electromagnetic radiation whose transverse electric field and intensity (irradiance) distributions are well approximated by Gaussian functions. Many lasers emit beams that approximate a Gaussian profile, in which case the laser is said to be operating on the fundamental transverse mode, or "TEM00 mode" of the laser's optical resonator. When refracted by a diffraction-limited lens, a Gaussian beam is transformed into another Gaussian beam (characterized by a different set of parameters), which explains why it is a convenient, widespread model in laser optics.

Mean time to failure (MTTF)

Mean time to failure (MTTF) is the length of time a device or other product is expected to last in operation. MTTF is one of many ways to evaluate the reliability of pieces of hardware or other technology. It's important to note, however, that the mean time to failure metrics provided by companies regarding specific products or components may not have been collected by running one unit continuously until failure. Instead, MTTF data is often collected by running many units, even many thousands of units, for a specific number of hours.

Laser Safety

The light emitted from these devices has been set in accordance with IEC60825. However, staring into the beam, whether directly or indirectly, must be avoided.

Class I

The maximum permissible exposure(MPE) cannot be exceeded, it includes High-power lasers within an enclosure that prevents exposure to the radiation and that cannot be opened without shutting down the laser. For example, a continuous laser at 600nm can emit up to 0.39mW, but for shorter wavelengths, the maximum emission is lower.

Class II

“Caution”, visible laser light less than 1.0mW. Considered eye safe, normal exposure to this type of beam will not cause permanent damage to the retina.

Class IIIA

“Danger”, visible laser light between 1.0mW and 5.0mW. Considered eye safe with caution. Focusing of this light into the eye could cause some damage.

Class IIIB

“Danger”, infrared(IR), and high power visible lasers considered dangerous to the retina if exposed. NB: it is important to note that while complying with the above classifications, unless otherwise stated. Our laser diode products are not certified and are designed solely for use in OEM products. The way in which device is used in the final product may alter its original design classification, and it is the responsibility of the OEM to ensure compliance with the relevant standards.

Specifications are subject to change without notice.

