

### Single Axis MEMS Scanning Mirror With Large Reflective Mirror

*E005BA is a single axis MEMS scanning mirror (MEMS scanner) providing high performance light beam scanning in a single silicon chip.*

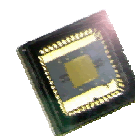

**E005BA**  
Single-axis  
MEMS scanning mirror

#### Features

- Large millimeter-size mirror capable of projecting & collecting reflected light beam
- Au or Al coated mirror to maximize optical reflectivity for selected wave length range
- Single-crystal silicon structure operated without mechanical wear
- Monolithic mirror & micro-actuator driven by electrostatic principle
- Low power consumption & ultra low noise
- Resonant operation for low scan jitter
- Compact and lightweight
- Standard PLCC (plastic leadless chip carrier) package
- Shock tolerant
- ROHS compliant

#### Applications

- Bar code scanning
- Laser area sensing
- LADAR (laser detection and range sensing)
- Non contact measurement and sensing
- Applications requiring line scan of laser beam

#### Contact

[info@eGismos.com](mailto:info@eGismos.com)

**EGISMOS TECHNOLOGY CORP.**

7278 Jubilee Ave.  
Burnaby BC V5J 4B6  
Canada

Tel: +1-888-348-1454

Fax: +1-604-433-9864

[www.eGismos.com](http://www.eGismos.com)

\*MEMS: Micro-Electro-Mechanical Systems, device fabricated by silicon micromachining processes

#### Specifications (Preliminary)

Mirror plate size	2.5x3.0 mm <sup>2</sup> / rectangular
Mirror reflectivity	> 90% ( $\lambda = 650\text{nm} @ 45^\circ$ )
Mirror resonant frequency	500Hz $\pm$ 10%
Mirror metallization	Au or Al
Power consumption	< 20 mW
Typical drive voltage	50 VAC p-p unipolar
Maximum drive voltage	60 VAC p-p unipolar
Typical scan angle	+/-25° (optical)
Maximum scan angle	+/-28° (optical)
Scan trajectory	Sinusoidal
Drive principle	Electrostatic
Operating temperature	0°-60°C
Operating humidity	10%-85%
Package footprint	10x10 mm <sup>2</sup>
Package	PLCC48

1. Mirror is resonantly operated
2. Scan angle adjustable by controlling amplitude or duty ratio of drive voltage signal
3. Exceeding maximum scan angle or maximum drive voltage may cause permanent damage to the mirror.

### TYPICAL PERFORMANCE CURVES:

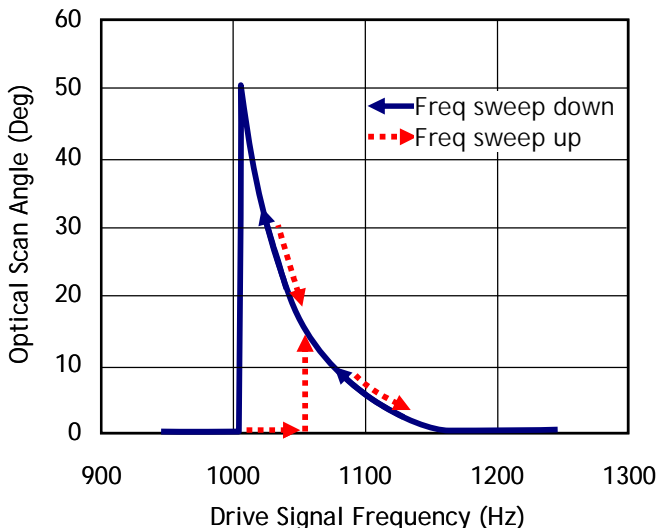

Figure 1. Typical Scan Angle vs. Drive Frequency with Constant Drive Signal Voltage

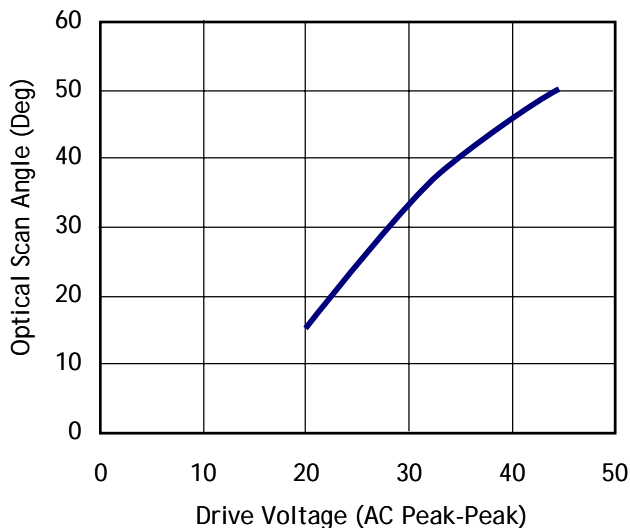

Figure 2. Typical Scan Angle vs. Drive Voltage with Constant Driving Frequency

### MIRROR SCAN TRAJECTORY VERSUS DRIVE SIGNAL:

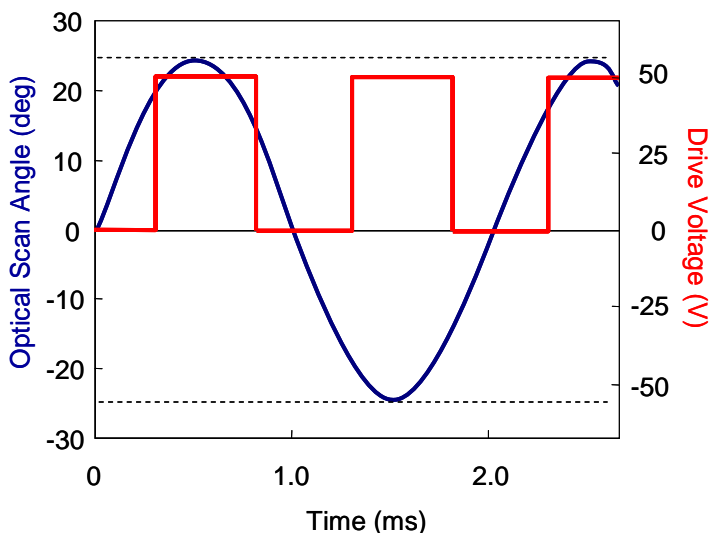

Figure 3. Typical Scan Trajectory Versus Drive Signal

Remarks:

1. Mirror scan trajectory is sinusoidal and scan frequency is half of drive signal frequency.
2. There is an inherent phase difference between drive signal and scan trajectory.
3. Mirror scanning can be started by sweeping drive signal frequency from high to desired operation point.
4. Mirror scanning can also be started by increasing duty ratio from low (5% typical) to 50% with fixed drive signal frequency.
5. Duty ratio exceeding 50% will not yield higher scan angle.
6. Stability of mirror scan is dominated by the stability of drive signal amplitude and frequency.

## PACKAGE OUTLINE & PIN ASSIGNMENT

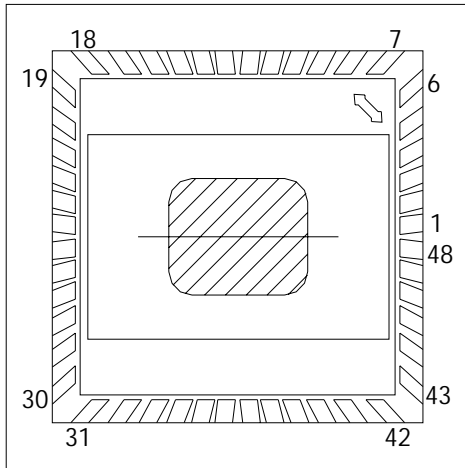

Figure 4. Package Drawing Top View

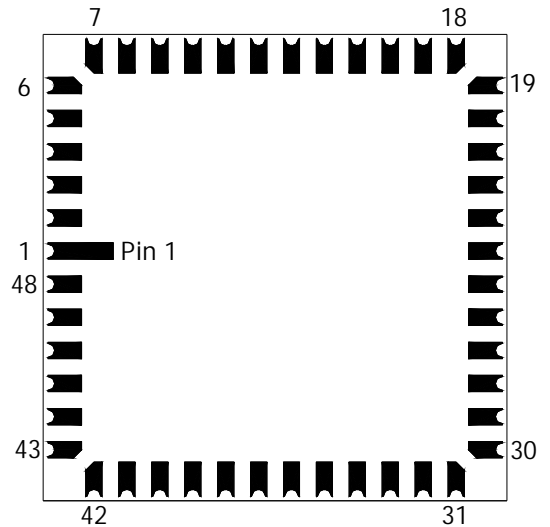

Figure 5. Package Drawing Bottom View

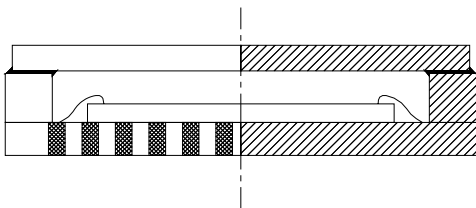

Figure 6. Package Drawing Side View

PIN #	DESCRIPTION
Pin 8/32	Drive Signal
Pin 17	GND
Pin 40	GND
Pin 41	GND
All other pins	Not Connected

Table 1. Pin Assignment