

Egismos *DATASHEET*

635nm Compact Laser Diode Modules Key features

Visible light $\lambda = 635\text{nm}$
Output powers $<1\text{mW}$, $<5\text{mW}$
Dimension: $6\text{mm} \times 12\text{mm}$
High reliability

Applications

Industrial alignment
Patient positioning

Laser Diode Solutions

The 635nm Compact Laser Diode Modules produce an elliptical, collimated output beam with output powers of $<1\text{mW}$ or $<5\text{mW}$. Operating voltage is from 2.6V to 6V DC at an operating current of 25~35mA typ ($<1\text{mW}$) or 50mA typ. ($<5\text{mW}$). Beam divergence is $<1\text{mrad}$ and operating temperature range is -10°C to $+50^\circ\text{C}$. The modules consist of a brass housing, laser diode, drive circuit and adjustable collimating/focusing lens.

Electrical connections are made via external flying leads. The lens may be adjusted to produce either a collimated beam or focused spot.

The compact design has made S63635/H63635 series elliptical beam laser diode modules suitable for general purpose OEM application.

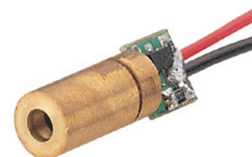

S63635
Laser Module

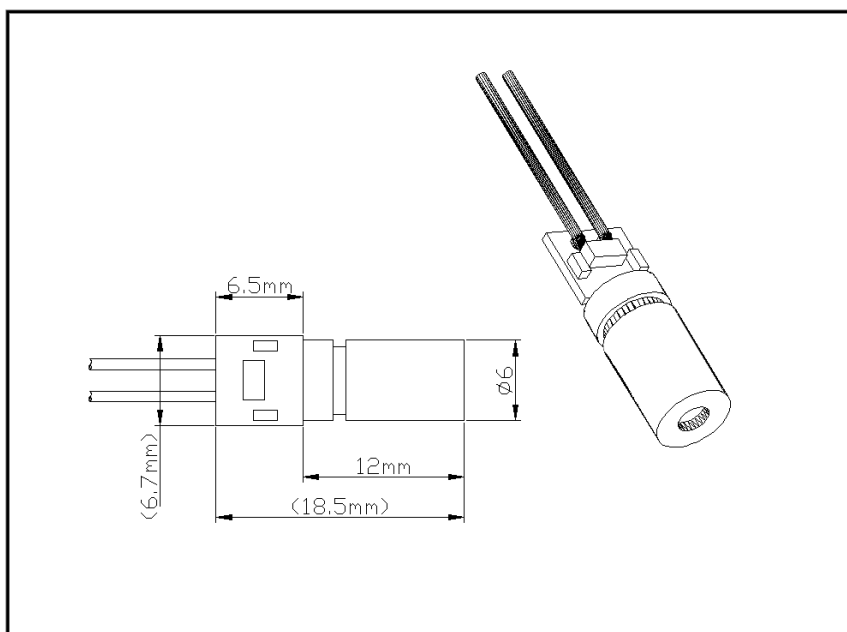

Egismos

<http://www.egismos.com>

TEL: +1-888-3481454

FAX: +1-604-4339864

E-Mail: sales@eGismos.com

Egismos *DATASHEET*

Specifications (typical @ $t_c=25^\circ\text{C}$)

| | | | |
|----------------------------|-----------------|---|--|
| Item. | symbol | S636351D S636355D | H636351D/R H636355D/R |
| Mode | | CW | CW |
| Wavelength | λ | 635nm | 635nm |
| Laser Pattern | | Dot | Dot/Rond |
| Dimeter x Length | $\Phi \times L$ | 6 x12 mm (w/o outside PCB) | 6 x12 mm (w/o outside PCB) |
| Output Power | P_o | <1mW, <5mW | 0.9mW \pm <10%, 3.2mW \pm <10% min. < 5% |
| Power Stability | | < 10% | < 2% |
| Collimated Beam Size | | <8x12mm at 10m | < 10mm round at 10m min.< 8mm at 10m |
| Collimated Beam Divergence | | <1mrad | <0.2mrad min.<0.1mrad |
| Operating Voltage(DC) | V_o | 2.6-6.0V | 2.6-6.0V |
| CW Operating Current | I_o | 25~35mA typ., 50mA max. | 25~35mA typ., 50mA max. |
| Operating Temperature | T_o | -10 $^\circ\text{C}$ to + 50 $^\circ\text{C}$ | -10 $^\circ\text{C}$ to +70 $^\circ\text{C}$ or Higher max. to +90 $^\circ\text{C}$ |
| Storage Temperature | | -40 $^\circ\text{C}$ to + 85 $^\circ\text{C}$ | -40 $^\circ\text{C}$ to + 120 $^\circ\text{C}$ |
| Bore Sight | | -- | <12mm/m min. < 5mm/m |
| Housing Material | | Brass/Aluminum | Brass/Aluminum |
| Mean time to failure(MTTF) | | >10,000 hrs | >10,000 hrs |



Laser Safety

The light emitted from these devices has been set in accordance with IEC60825. However, staring into the beam, whether directly or indirectly, must be avoided. IEC60825 classifies laser products into three different categories depending on light emitted, wavelength and eye safety.

CLASS II

"Caution", visible laser light less than 1.0mW. Considered eye safe, normal exposure to this type of beam will not cause permanent damage to the retina.

CLASS IIIR

"Danger", visible laser light between 1.0mW and 5.0mW. Considered eye safe with caution. Focusing of this light into the eye could cause some damage.

CLASS IIIB

"Danger", infrared (IR), and high power visible lasers considered dangerous to the retina if exposed. N B: It is important to note that while complying with the above classifications, unless otherwise stated, our laser diode products are not certified and are designed solely for use in OEM products. The way in which the device is used in the final product may alter its original design classification, and it is the responsibility of the OEM to ensure compliance with the relevant standards.



<http://www.egismos.com>

TEL:+1-888-3481454

FAX:+1-604-4339864

E-Mail:sales@eGismos.com