

Egismos *DATASHEET*

650nm Compact Laser Diode Modules Key features

Wavelength λ :650nm

Output power :<1mW, <5mW

Dimension: 9mm x 21mm

Housing:Hard anodized aluminum or Brass

High reliability



Laser Diode Solutions

The 650nm Industrial Laser Diode Modules produce an elliptical, collimated output beam with output powers of <1mW or <5mW. Operating voltage is from 2.6V to 6V DC at an operating current of 25~35mA typ (<1mW) or 40mA typ.<5mW) .

Beam divergence is <0.1 for H series.

The modules consist of a metallic housing, laser diode, drive circuit and adjustable collimating/focusing lens.

Electrical connections ,including optional TTL modulation signal, are made via external flying leads. The lens may be adjusted to produce either a collimated beam or focused spot.

The S8 and H8 range of laser modules has been designed as a complete laser diode solution for OEM use in diverse applications such as industrial alignment and positioning ,medical fluorescence and bar code readers.

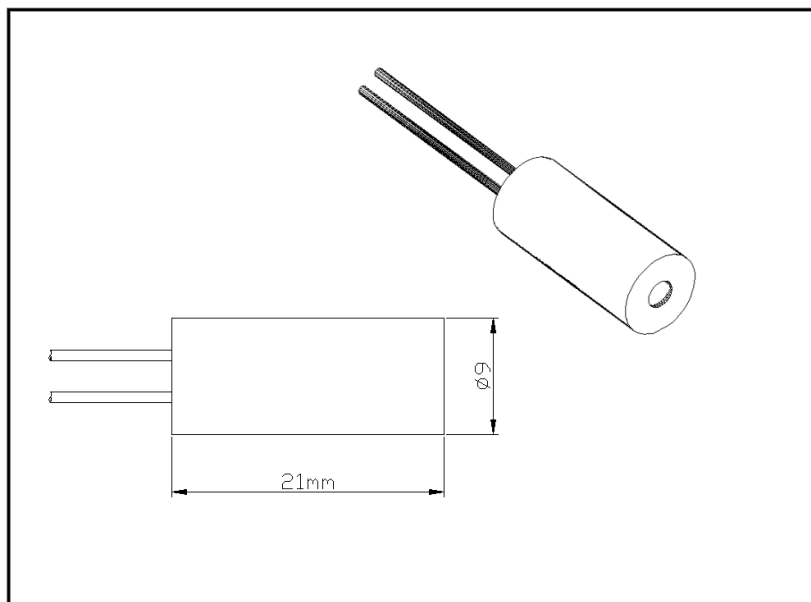

Egismos

<http://www.egismos.com>

TEL:+1-888-3481454

FAX:+1-604-4339864

E-Mail:sales@eGismos.com

EGISMOS *DATASHEET*

Specifications (typical @ $t_c = 25^\circ\text{C}$)

Item.	symbol	S936501D/L/C/R S936505D/L/C/R	H936501D/L/C/R H936505D/L/C/R
Mode		CW	CW
Wavelength	λ	650nm	650nm
Laser Pattern		Dot/Line/Cross/Round	Dot/Line/Cross/Round
Dimeter x Length	$\Phi \times L$	9 x 21 mm	9 x 21 mm
Output Power	P_o	<1mW, <5mW	0.9mW \pm <10%, 3.2mW \pm <10% min. < 5%
Power Stability		< 10%	< 2%
Collimated Beam Size		<8x12mm at 10m	< 10mm round at 10m min. < 8mm at 10m
Collimated Beam Divergence		<1mrad	<0.2mrad min. < 0.1mrad
Operating Voltage(DC)	V_o	2.6-6.0V	2.6-6.0V
CW Operating Current	I_o	25~35mA typ., 50mA max.	25~35mA typ., 50mA max.
Operating Temperature	T_o	-10 $^\circ\text{C}$ to + 50 $^\circ\text{C}$	-10 $^\circ\text{C}$ to +70 $^\circ\text{C}$ or Higher max. to +90 $^\circ\text{C}$
Storage Temperature		-40 $^\circ\text{C}$ to + 85 $^\circ\text{C}$	-40 $^\circ\text{C}$ to +120 $^\circ\text{C}$
Bore Sight		--	<12mm/m min. < 5mm/m
Span Angle		90 $^\circ \pm 5^\circ$ for Line/Cross	Any angle $\pm 2^\circ$ for Line/Cross
Houseing Material		Brass/Aluminum	Brass/Aluminum
Mean time to failure(MTTF)		>10,000 hrs	>10,000 hrs



Laser Safety

The light emitted from these devices has been set in accordance with IEC60825. However, staring into the beam, whether directly or indirectly, must be avoided. IEC60825 classifies laser products into three different categories depending on light emitted, wavelength and eye safety.

CLASS II

"Caution", visible laser light less than 1.0mW. Considered eye safe, normal exposure to this type of beam will not cause permanent damage to the retina.

CLASS IIIA

"Danger", visible laser light between 1.0mW and 5.0mW. Considered eye safe with caution. Focusing of this light into the eye could cause some damage.

CLASS IIIB

"Danger", infrared (IR), and high power visible lasers considered dangerous to the retina if exposed. NB: It is important to note that while complying with the above classifications, unless otherwise stated, our laser diode products are not certified and are designed solely for use in OEM products. The way in which the device is used in the final product may alter its original design classification, and it is the responsibility of the OEM to ensure compliance with the relevant standards.



<http://www.egismos.com>
 TEL: +1-888-3481454
 FAX: +1-604-4339864
 E-Mail: sales@eGismos.com