

HIGH POWER APC LASER DIODE DRIVER

FEATURES

- Automatic Power Control CW operation driving current up to 350mA
- Wide supply voltage from 2.1 to 6VDC, provided $(VDD-V(LD)) \times I(LDA) < 0.4W$
- APC TTL modulation frequency up to 20KHz, with adjustable duty cycle
- Rapid soft start after power-on
- Simple power adjustment via the external resistor
- Control loop accuracy up to 1% with changes in temperature
- Permanent shutdown with excessive temperature and pre-set current limit
- Wide monitor current range from 10 μ A to 0.5mA
- Worldwide laser safety regulations compliant, including TUV, JQA, CE and FDA
- Variable package type available, including Known Good Die, SOT26 and SOP8
- Support N type laser diode package

APPLICATIONS

- Laser Leveling
- Bar Code Reader
- Laser Measuring Equipment
- Laser Medical Equipment
- Diode Pumping Laser Driver

LOCK DIAGRAM

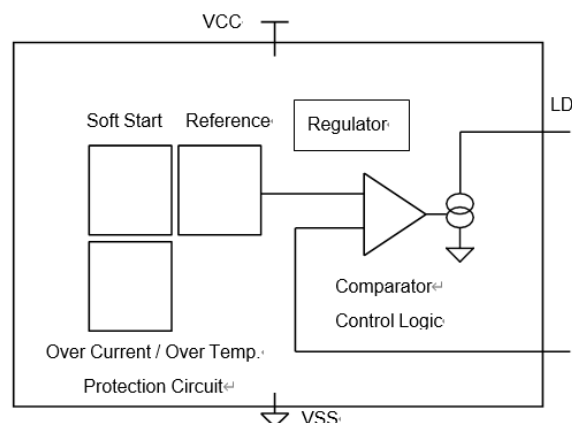

PIN CONFIGURATION (For EDL2M-SOP8, pin name applicable to KGD and SOT26)

No.	Name	Function
1	MDA	Photo Diode (PD or MD) Anode
2	GND	Ground
3	SS	Soft Start Ramping Control
4	LDA	Driver Output (LD Anode)
5	VDD	+2.1~ 6V Supply Voltage
6	PRO	Max Driving Current Control
7	OSC	Built-in Oscillation Output
8	EN	Enable or TTL signal Input

PIN CONFIGURATION (For EDL2J-SOT26)

No.	Name	Function
1	PRO	Max Driving Current Control for Protecting
2	VDD	+2.1-6V Supply Voltage
3	SS	Soft Start Ramping Control
4	LDA	Driver Output (LD Anode)
5	GND	Ground
6	MDA	Photo Diode (PD or MD) Anode

APPLICATION CONNECTION

- KGD Pinout
- SOT26
- SOP8

EDL2-DIE

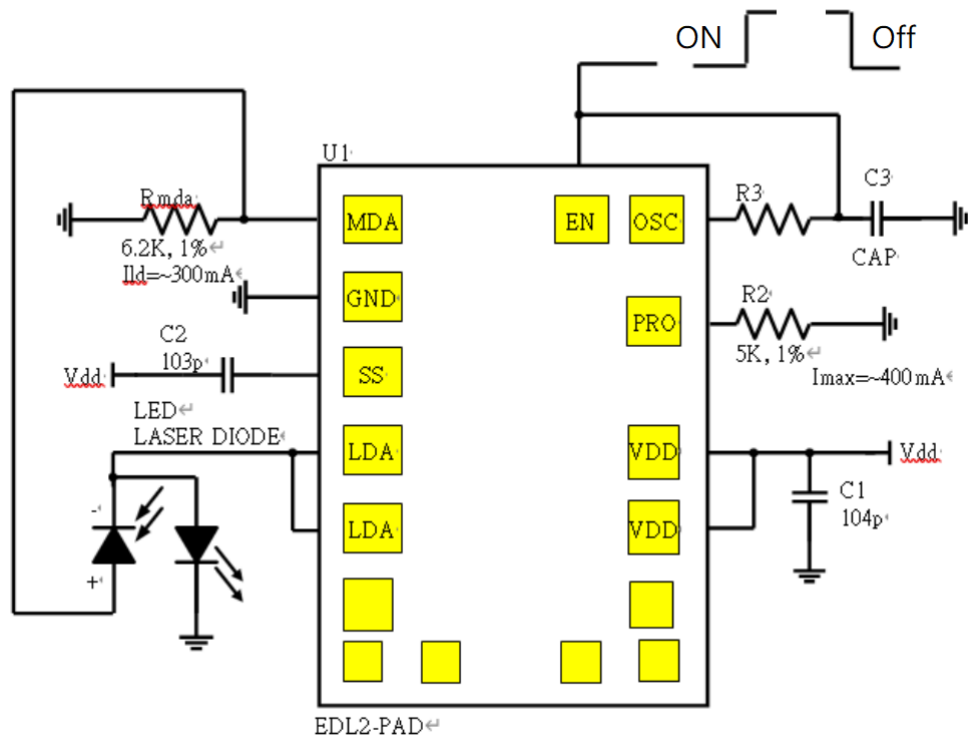

EDL2J-SOT26

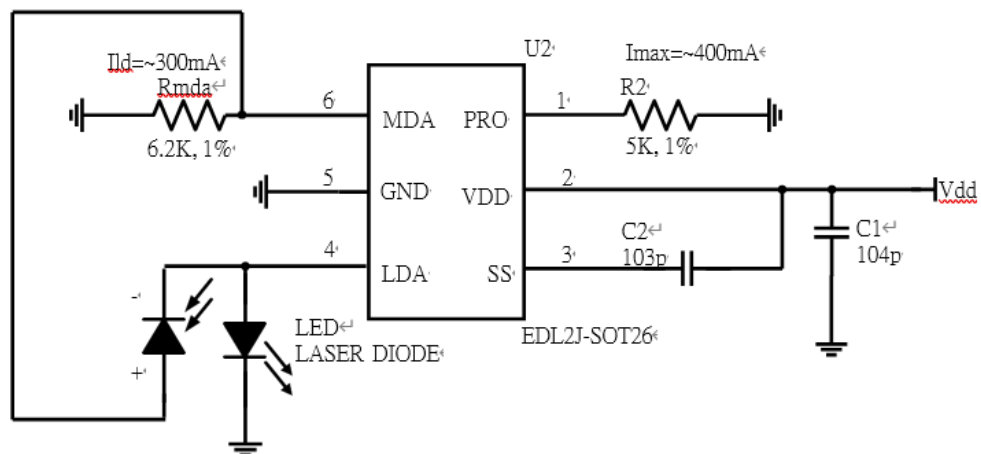

EDL2M-SOP08

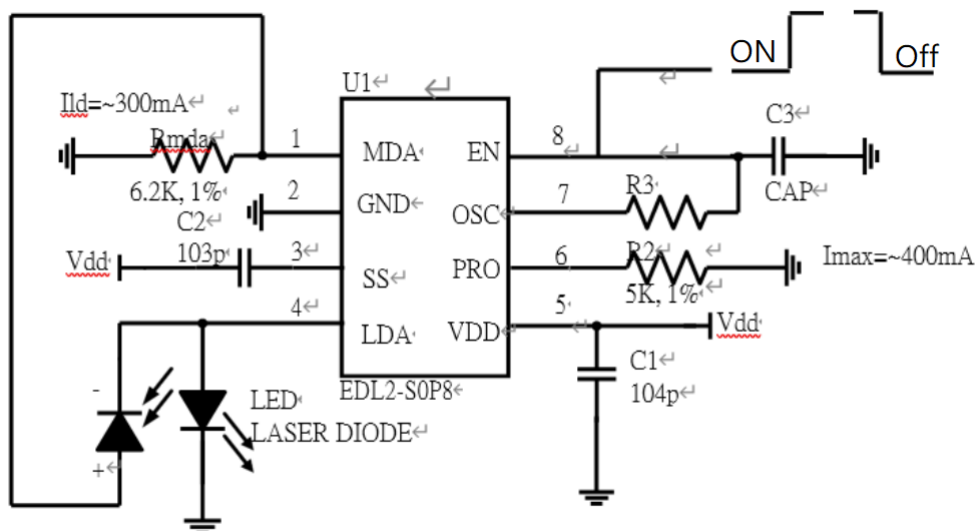

DESCRIPTION

The EDL2 High Power APC Laser Diode Driver device is a driver and controller for laser diodes in both continuous wave and up to 20KHz TTL modulation operation which requires only few external components. The broad power supply range of 2.1V to 6V and the integrated reverse battery protection allow for battery operation with a minimum of two cells.

The driver includes integrated circuitry protecting against destruction by ESD, excessive temperature and over current and a soft start which regulates the power and protects the laser diode when the power supply is switched on. The driver also filters the laser diode power supply for transients.

The power supply is regulated and adapted for the laser diode used by an external resistor at PD. The monitor current acts as a reference and is regulated independent of the influence of temperature and supply voltage (range: 10µA to 0.5mA). It is designed to meet the stringent worldwide laser safety regulation, TUV, JQA, CE and FDA etc, requirement and the harsh industrial operation environment.

In the event of failure, such as over current in the laser path with a lack of feedback, for example, a quick power lockout is activated. The shutdown continues until power is reapplied, permitting a restart. The strain

on power packs and batteries is relieved and the laser class is retained even in the event of a disturbance.

Given the tiny package size, the maximum allowable power dissipation over EDL2 is recommended to be less than 0.4W. For example, if V_{op} of a given laser diode is 2.5VDC, the allowable I_{op} and VDD combination can be 6VDC, with I_{op} of laser diode less than 110mA; or 3VDC, with I_{op} less than 350mA. The rule of thumb is $(VDD - V_{op}) \times I_{op} \leq 0.4W$.

ABSOLUTE MAXIMUM RATINGS

Beyond these values damage may occur; device operation is not guaranteed.

Symbol	Parameter	Conditions	Min.	Typ.	Max.	Unit
VDD	Voltage at VDD		-0.5		7	V
I(VCC)	Current in VDD		-100		600	mA
I(LDA)	Current in LD				500	mA
I(MDA)	Current in PD				6	mA
VR	Reverse Voltage				-4	V
VD	ESD Susceptibility at all pins	MIL-STD-883, Method 3015, HBM 100pF discharged through 1.5kS			1	kV
Tsoldering	Soldering Temperature	260°C for 10 seconds (SOIC)*				
Tj	Operating Junction Temperature		-40		150	°C
Ts	Storage Temperature Range		-55		125	°C

*See IPC/JEDEC Standard J-STD-020A for Surface Mount Devices.

LASER MODULE LAYOUT EXAMPLE

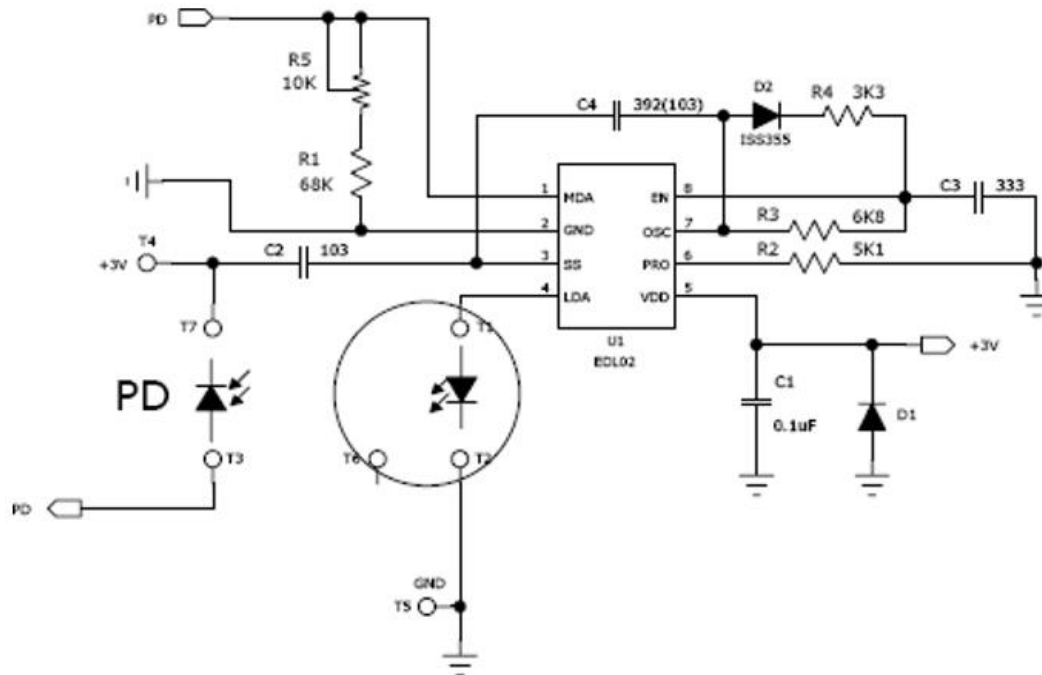

Reference for over current protection

LDA output protect current $\approx 1.2 \cdot 1600 / R2$ and the value differs from the different Vdd and the tolerance of passive components.

Reference for output power adjustment

$$I_{(MDA)} = 1.2 / R_{mda}, \text{ where } I_{(MDA)} \propto P_o.$$

1. Laser output power adjustment: R1+R5
2. Max laser diode driving current limit: R2
3. TTL modulation frequency adjustment: R3, C3
4. TTL modulation duty cycle adjustment: R4, D2
5. Soft start turn-on delay control: C2

Reference layout design (For two layers PCB)

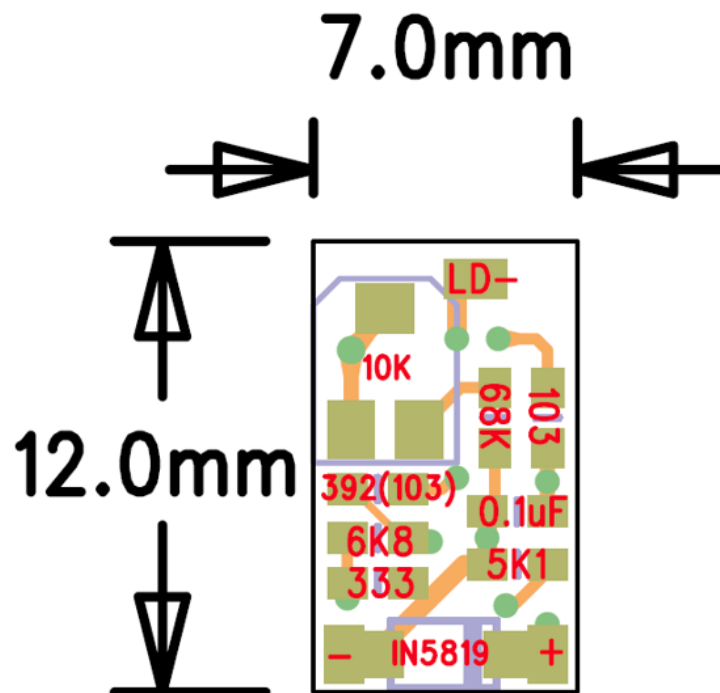
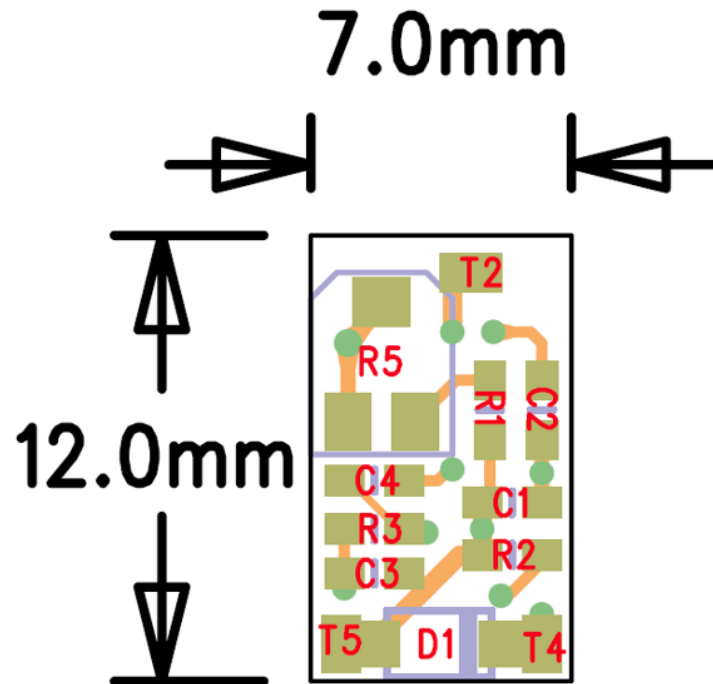

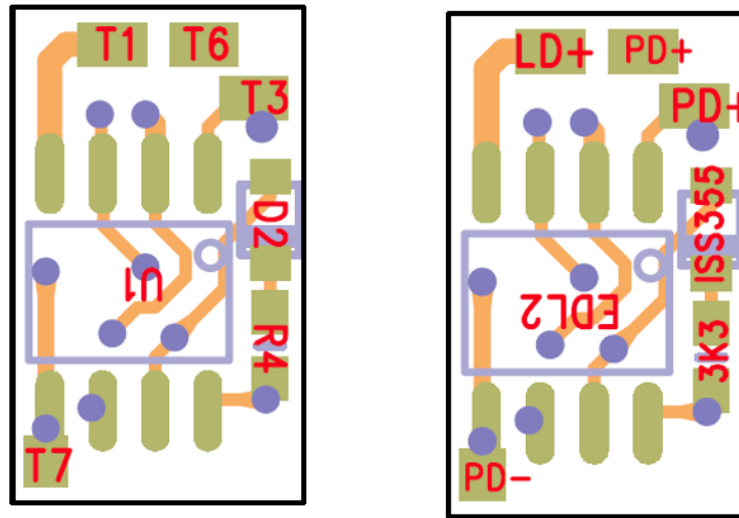

Demo board operation procedure

1. Adjust R5 to max value, 20K ohm is recommended <- VERY IMPORTANT!
2. Decide the best Vop and Iop of laser diode combination by referring to allowable power consumption equation $(VDD - Vop) \times Iop \leq 0.5W$
3. Set max. driving current limit for overcurrent protection by adjusting R2
4. Set soft start delay time by adjusting C2
5. For continuous wave operation, leave EN and OSC open, go directly to the final step
6. For TTL modulation operation, adjusting R3, C3 for desired modulation frequency
7. For TTL modulation operation, adjusting D2, R4 for desired duty cycle ratio. Forward biased D2, as shown in schematic, leads to extended High ratio; Reversed biased D2 leads

to extended Low ratio

8. The value of C4 affects both soft start delay time Tss and max. TTL modulation frequency. In order to stabilize LDA output current, C2 + C4 should be in between 500pf~ 1500pF. The ratio of C4/C2 depends on target LDA current, for higher LDA current, higher C4/C2 ratio is suggested.
9. For external TTL modulation signal input, remove R3, C3, R4, and D2, and connect TTL signal, square wave, directly to EN
10. EN pin is Schmitt trigger input with $V_{ih} \sim 1.45V$, $V_{il} \sim 0.95V$ @ $V_{dd} = 3V$
11. Adjusting R5 to obtain desired laser power output

SOT26 Package Drawing

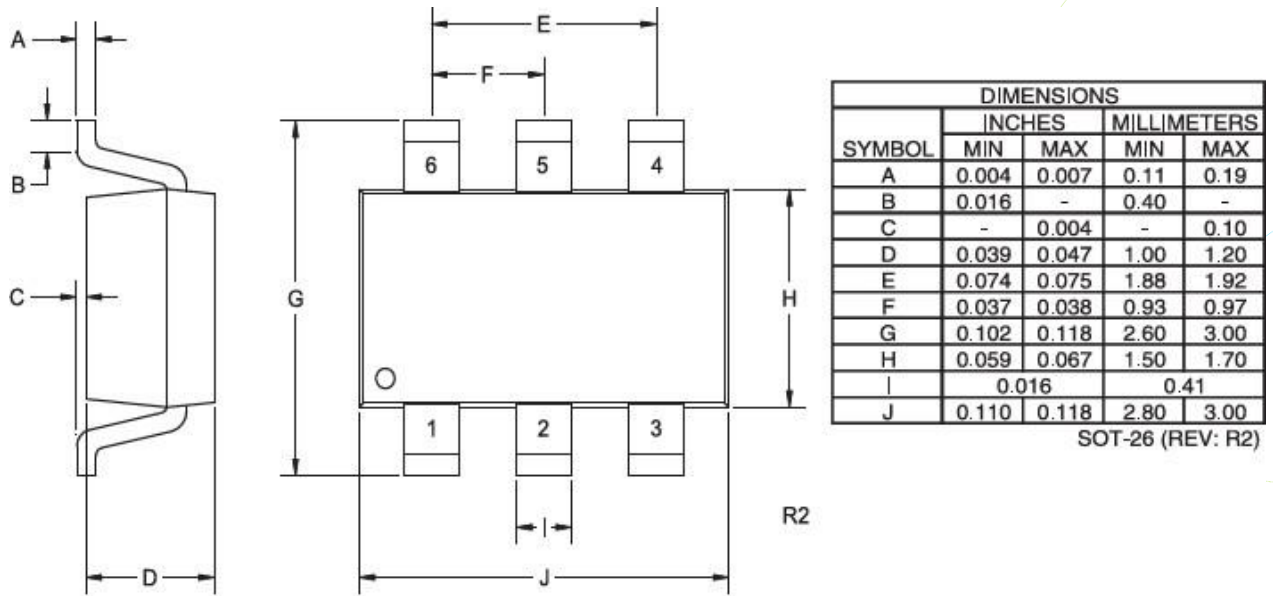

Lead Code:
Reference individual device datasheet.

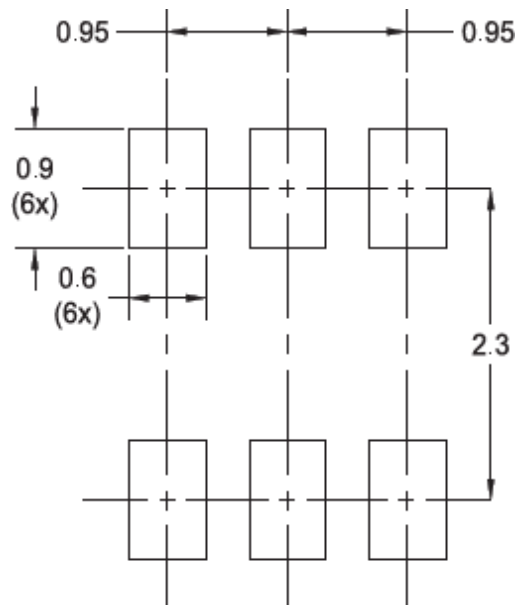

SOP8 Package Drawing

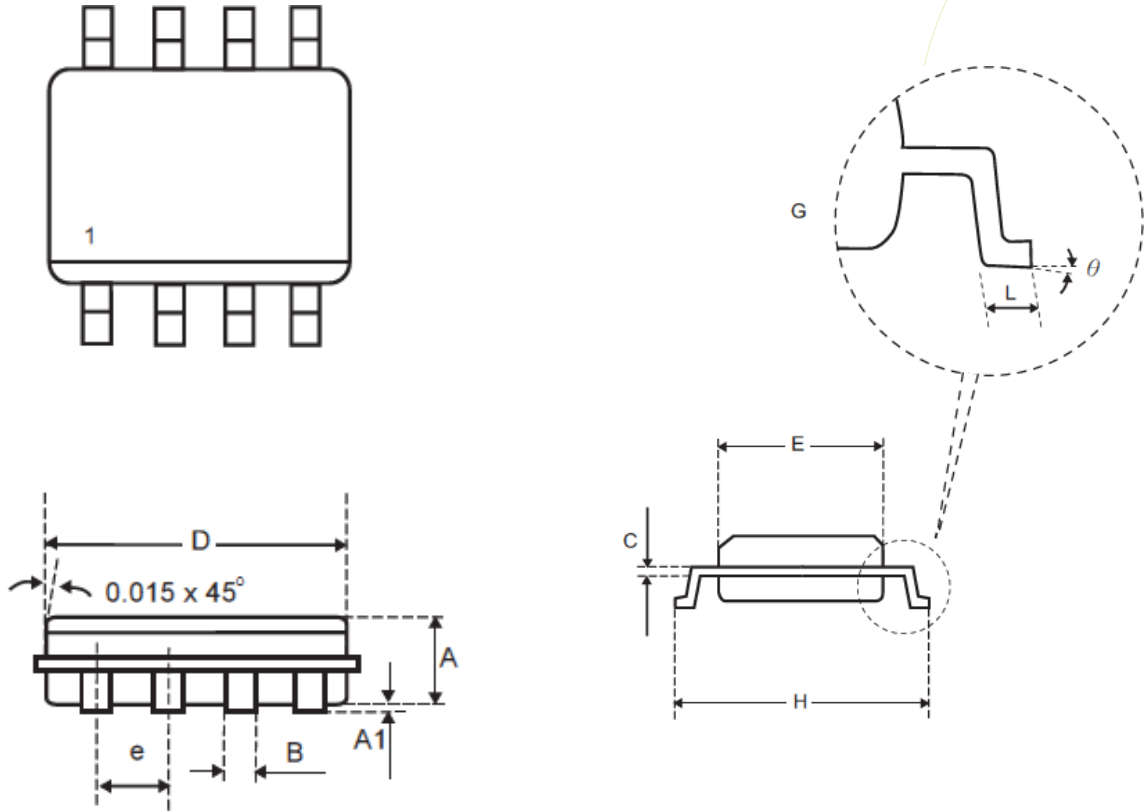

SYMBOLS	MILLIMETERS		INCHES	
	Min.	Max.	Min.	Max.
A	1.35	1.75	0.053	0.069
A1	0.10	0.25	0.004	0.010
B	0.41 Typ.		0.016 Typ.	
C	0.20 Typ.		0.008 Typ.	
D	4.80	4.98	0.189	0.196
E	3.81	3.99	0.150	0.157
e	1.25 Typ.		0.05 Typ.	
H	5.79	6.20	0.228	0.244
L	0.41	1.27	0.016	0.050
θ	0°	8°	0°	8°